



www.2ktechnologies.in

Company Introduction

Technology for Green Building Materials

© 2K Technologies, India 2024

**Founded in
2000**

Founders

Stalwarts from India's Largest Building Products Manufacturer

Over 60 years of design, process and technology development experience

**Company
Vision**

To enhance, develop and promote state-of-the-art building products technologies

**Company
Mission**

To ensure the success of our clients in producing building products of high quality

Positioning

2K positions itself as an end-to-end technology provider which includes supply of plant and process technology with new-age automation systems

History



Non Asbestos Fiber Cement Flat and Corrugated Sheets

Aerated Sandwich Panels

EPS Sandwich Panels

Lightweight Calcium Silicate Ceiling Tiles and Insulations Blocks

Calcium Silicate Flat sheets and Boards

Complete production line and sub equipment to support above mention process

Technology, Plant & Equipment



Engineering & Plant Design

Process Development

Process transparency/ visualization/reporting and control

Factory/process Upgrade

Production Optimization

Process Automation

Quality Enhancement

Fine Tuning & Troubleshooting

Services



Strength

Over 150 man years of management industry experience

Over 200 man years of employee industry experience

Over 25 complete plants installed and running

Over 30 customers worldwide

Single repeat customer running seven plants from 2K



USP

End-to-end technology provider with in-house process, engineering, fabrication, electrical, automation, pneumatics and hydraulics systems knowhow

Hands-on plant operation, process and production background

Pride in after sales service and support

Strength & USP

Design

2K has state of the art own design office where we use the latest 3D CAD software for designing and modelling fibre cement processes and equipment.

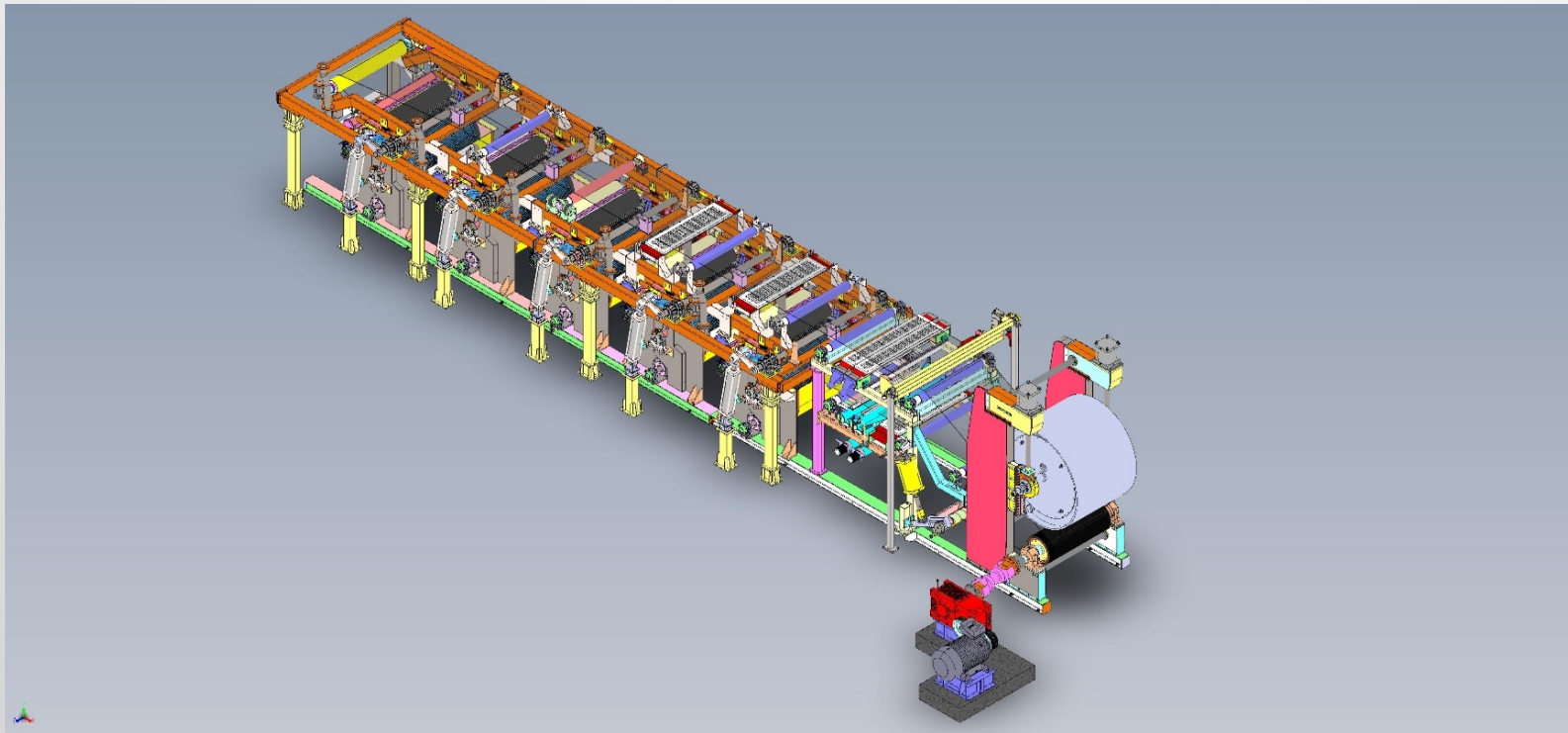

Automation and Control

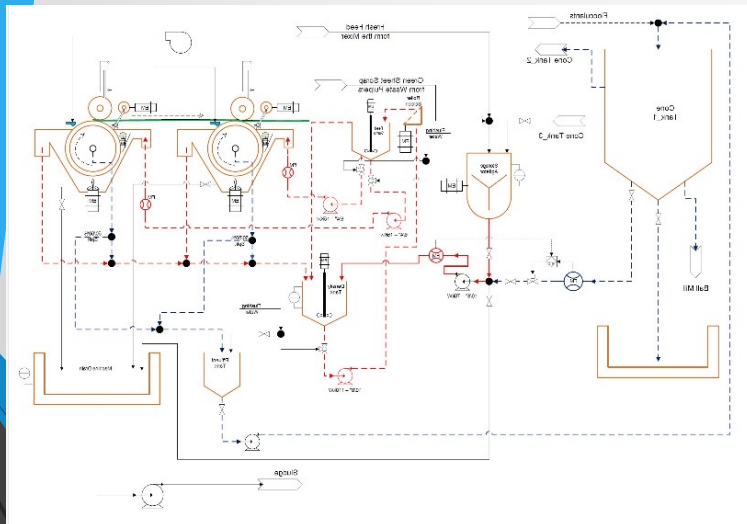
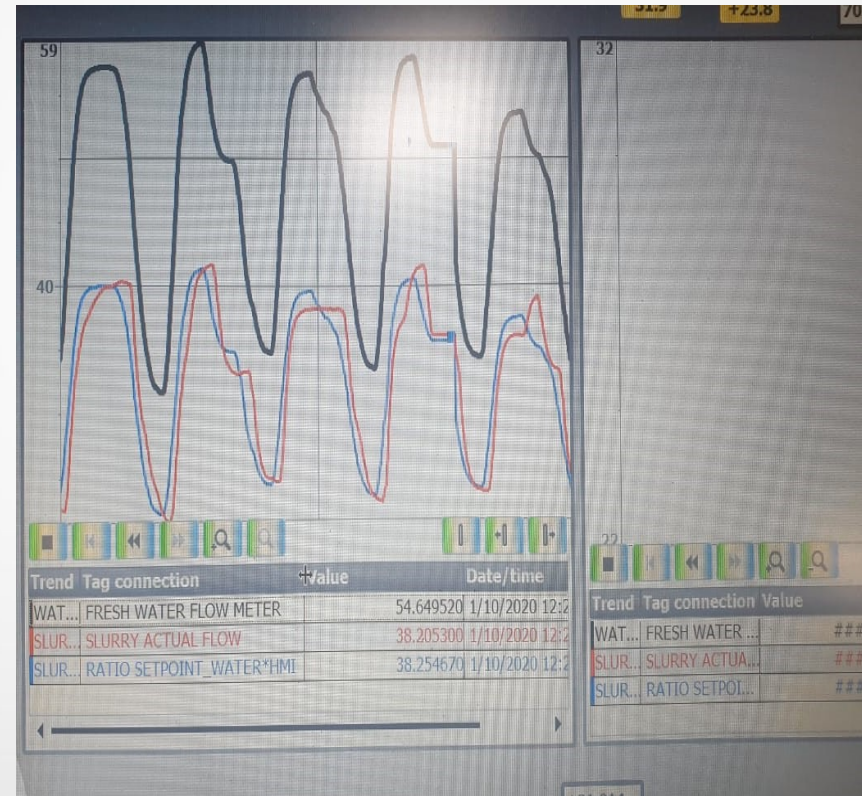
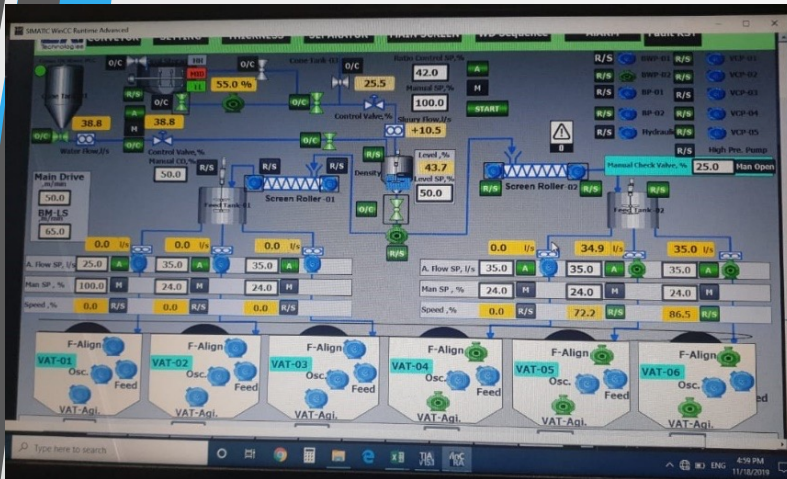



Raw Material
Section



Sheet Forming
Drum



Sheet Machine



ATHS Car



Stacker



Destacker

Gallery

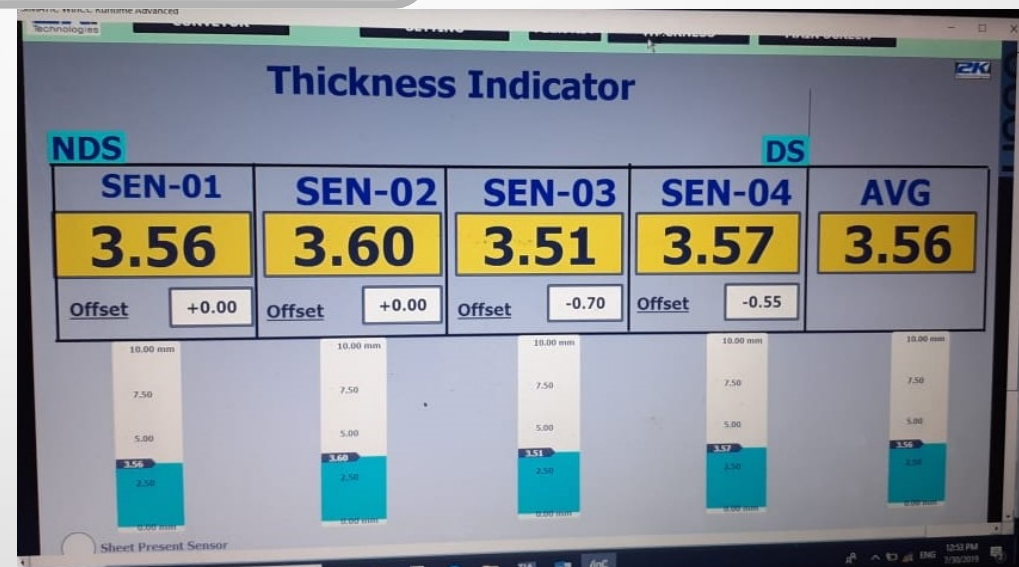

Fiber Cement Flat Sheets

| PT Djabesmen, Indonesia | Royal Board, Indonesia

Dong Nai Roof Sheet & Contracting, Vietnam | Built Element , Sri Lanka

Sri Ramco Lanka, Sri Lanka | Jaypee Group, India | Ramco Industries Ltd., India | Utkal Asbestos Ltd., India

Assam Roofing Ltd., India | Visaka Industries Ltd., India | Gujarat Composites Ltd.,

India | U.P. Asbestos, India | Everest Industries Ltd., India | Ankit Pipes Pvt. Ltd.,

India | ARL Infratech Ltd., India | Anwar Cement Sheet Ltd., Bangladesh

Moriom Cement Sheet Mills Ltd., Bangladesh | Shamoli Cement Sheet Mills Ltd., Bangladesh

Turnall Holdings Ltd., Zimbabwe | UP Asbestos Ltd., India

Partial Client List